

YPMill VS

多材料通用平头铣刀

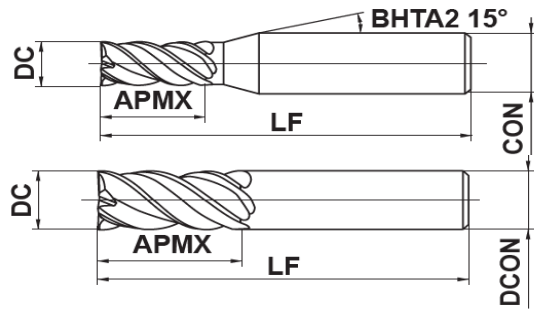

刀型 1

刀型 2

柄部直径公差	h6
螺旋角FHA	36°
刀尖形状	DC≤12, 0.10×45° DC>12, 0.15×45°

订货号	尺寸 (mm)				刃数 ZEFP	DC公差 TCDC	刀型
	DC	APMX	LF	DCON			
VS2S-D0020-C-0040-L50	0.2	0.4	50	4	2	0/-0.01	1
VS2S-D0030-C-0060-L50	0.3	0.6	50	4	2	0/-0.01	1
VS2S-D0040-C-0080-L50	0.4	0.8	50	4	2	0/-0.01	1
VS2S-D0050-C-0100-L50	0.5	1	50	4	2	0/-0.01	1
VS2S-D0060-C-0120-L50	0.6	1.2	50	4	2	0/-0.01	1
VS2S-D0070-C-0140-L50	0.7	1.4	50	4	2	0/-0.01	1
VS2S-D0080-C-0160-L50	0.8	1.6	50	4	2	0/-0.01	1
VS2S-D0090-C-0180-L50	0.9	1.8	50	4	2	0/-0.01	1
VS4S-D0100-C-0300-L50	1	3	50	4	4	0/-0.01	2
VS4S-D0150-C-0450-L50	1.5	4.5	50	4	4	0/-0.01	2
VS4S-D0200-C-0600-L50	2	6	50	4	4	0/-0.01	2
VS4S-D0250-C-0700-L50	2.5	7	50	4	4	0/-0.01	2
VS4S-D0300-C-0900-L50	3	9	50	4	4	0/-0.012	2
VS4S-D0400-C-1000-L50	4	10	50	4	4	0/-0.012	2
VS4S-D0400-C-1200-L75	4	12	75	4	4	0/-0.012	2
VS4S-D0400-C-1200-L100	4	12	100	4	4	0/-0.012	2
VS4S-D0200-C-0500-L50	2	5	50	6	4	0/-0.012	2
VS4S-D0300-C-0800-L50	3	8	50	6	4	0/-0.012	2
VS4S-D0400-C-1000-L50	4	10	50	6	4	0/-0.012	2
VS4S-D0500-C-1300-L50	5	13	50	6	4	0/-0.012	2
VS4S-D0600-C-1500-L50	6	15	50	6	4	0/-0.015	2
VS4S-D0600-C-1500-L75	6	15	75	6	4	0/-0.015	2
VS4S-D0600-C-1500-L100	6	15	100	6	4	0/-0.015	2
VS4S-D0800-C-2000-L60	8	20	60	8	4	0/-0.015	2
VS4S-D0800-C-2500-L75	8	25	75	8	4	0/-0.015	2
VS4S-D0800-C-3200-L100	8	32	100	8	4	0/-0.015	2
VS4S-D0800-C-3200-L150	8	32	150	8	4	0/-0.015	2
VS4S-D1000-C-2500-L75	10	25	75	10	4	0/-0.015	2
VS4S-D1000-C-4000-L100	10	40	100	10	4	0/-0.015	2
VS4S-D1000-C-4000-L150	10	40	150	10	4	0/-0.015	2
VS4S-D1200-C-3000-L75	12	30	75	12	4	0/-0.02	2
VS4S-D1200-C-5000-L100	12	50	100	12	4	0/-0.02	2
VS4S-D1200-C-5000-L150	12	50	150	12	4	0/-0.02	2
VS4S-D1400-C-4000-L100	14	40	100	14	4	0/-0.02	2
VS4S-D1400-C-5500-L150	14	55	150	14	4	0/-0.02	2
VS4S-D1600-C-4000-L100	16	40	100	16	4	0/-0.02	2
VS4S-D1600-C-6000-L150	16	60	150	16	4	0/-0.02	2
VS4S-D1800-C-4500-L100	18	45	100	18	4	0/-0.02	2
VS4S-D1800-C-6500-L150	18	65	150	18	4	0/-0.02	2
VS4S-D2000-C-5000-L100	20	50	100	20	4	0/-0.02	2
VS4S-D2000-C-7000-L150	20	70	150	20	4	0/-0.02	2

YPMill VB

多材料通用球头铣刀

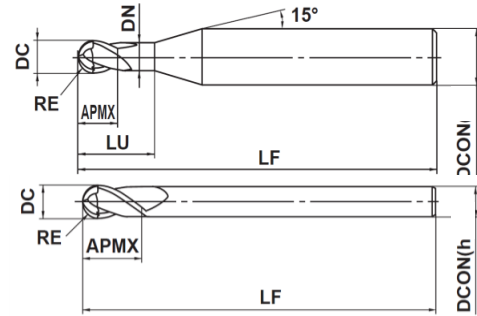

刀型 1

刀型 2

柄部直径公差	h6
螺旋角FHA	30°
球头R公差	±0.005

订货号	尺寸 (mm)							刃数 ZEFP	刀型
	DC	RE	APMX	LF	LU	DN	DCON		
VB2S-D0020-R0010-0020-L50	0.2	0.1	0.2	50	-	-	4	2	1
VB2S-D0030-R0015-0030-L50	0.3	0.15	0.3	50	-	-	4	2	1
VB2S-D0040-R0020-0060-L50	0.4	0.2	0.6	50	-	-	4	2	1
VB2S-D0050-R0025-0080-L50	0.5	0.25	0.8	50	-	-	4	2	1
VB2S-D0060-R0030-0090-L50	0.6	0.3	0.9	50	-	-	4	2	1
VB2S-D0080-R0040-0120-L50	0.8	0.4	1.2	50	-	-	4	2	1
VB2S-D0100-R0050-0150-L50	1	0.5	1.5	50	-	-	4	2	1
VB2S-D0120-R0060-0180-L50	1.2	0.6	1.8	50	-	-	4	2	2
VB2S-D0150-R0075-0230-L50	1.5	0.75	2.3	50	-	-	4	2	2
VB2S-D0200-R0100-0300-L50	2	1	3	50	-	-	4	2	2
VB2S-D0300-R0150-0450-L50	3	1.5	4.5	50	-	-	4	2	2
VB2S-D0400-R0200-0600-L50	4	2	6	50	-	-	4	2	2
VB2S-D0400-R0200-0600-L75	4	2	6	75	-	-	4	2	2
VB2S-D0400-R0200-0800-L100	4	2	8	100	-	-	4	2	2
VB2S-D0100-R0050-0150-DCON6	1	0.5	1.5	50	-	-	6	2	2
VB2S-D0150-R0075-0230-DCON6	1.5	0.75	2.3	50	-	-	6	2	2
VB2S-D0200-R0100-0300-DCON6	2	1	3	50	-	-	6	2	2
VB2S-D0300-R0150-0450-DCON6	3	1.5	4.5	50	-	-	6	2	2
VB2S-D0400-R0200-0600-DCON6	4	2	6	50	-	-	6	2	2
VB2S-D0500-R0250-0750-L50	5	2.5	7.5	50	-	-	6	2	2
VB2S-D0600-R0300-0900-L50	6	3	9	50	-	-	6	2	2
VB2S-D0600-R0300-0900-L75	6	3	9	75	-	-	6	2	2
VB2S-D0600-R0300-1200-L100	6	3	12	100	-	-	6	2	2
VB2S-D0800-R0400-1200-L60	8	4	12	60	-	-	6	2	2
VB2S-D0800-R0400-1200-L75	8	4	12	75	-	-	8	2	2
VB2S-D0800-R0400-1600-L100	8	4	16	100	-	-	8	2	2
VB2S-D0800-R0400-1600-L150	8	4	16	150	-	-	8	2	2
VB2S-D1000-R0500-1500-L75	10	5	15	75	-	-	10	2	2
VB2S-D1000-R0500-2000-L100	10	5	20	100	-	-	10	2	2
VB2S-D1000-R0500-2000-L150	10	5	20	150	-	-	10	2	2
VB2S-D1200-R0600-1800-L75	12	6	18	75	-	-	12	2	2
VB2S-D1200-R0600-2400-L100	12	6	24	100	-	-	12	2	2
VB2S-D1200-R0600-2400-L150	12	6	24	150	-	-	12	2	2
VB2S-D1400-R0700-2100-L100	14	7	21	100	-	-	14	2	2
VB2S-D1400-R0700-2800-L150	14	7	28	150	-	-	14	2	2
VB2S-D1600-R0800-2400-L100	16	8	24	100	-	-	16	2	2
VB2S-D1600-R0800-3200-L150	16	8	32	150	-	-	16	2	2
VB2S-D1800-R0900-2700-L100	18	9	27	100	-	-	18	2	2
VB2S-D1800-R0900-3600-L150	18	9	36	150	-	-	18	2	2
VB2S-D2000-R1000-3000-L100	20	10	30	100	-	-	20	2	2
VB2S-D2000-R1000-4000-L150	20	10	40	150	-	-	20	2	2

YPMill VR



多材料通用圆鼻铣刀

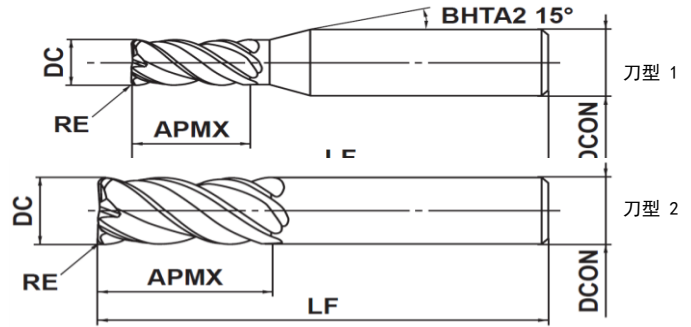

柄部直径公差	h6
螺旋角FHA	37° 40°
刀尖圆弧R公差	±0.02

订货号	尺寸 (mm)					刃数 ZEFZ	DC公差 TCDC	刀型
	DC	RE	APMX	LF	DCON			
VR4S-D0100-R0010-0200-L50	1	0.1	2	50	4	4	0/-0.01	1
VR4S-D0100-R0020-0200-L50	1	0.2	2	50	4	4	0/-0.01	1
VR4S-D0150-R0010-0300-L50	1.5	0.1	3	50	4	4	0/-0.01	1
VR4S-D0150-R0020-0300-L50	1.5	0.2	3	50	4	4	0/-0.01	1
VR4S-D0200-R0100-0400-L50	2	1	4	50	4	4	0/-0.01	1
VR4S-D0200-R0020-0400-L50	2	0.2	4	50	4	4	0/-0.01	1
VR4S-D0200-R0030-0400-L50	2	0.3	4	50	4	4	0/-0.01	1
VR4S-D0300-R0010-0600-L50	3	0.1	6	50	4	4	0/-0.01	1
VR4S-D0300-R0020-0600-L50	3	0.2	6	50	4	4	0/-0.01	1
VR4S-D0300-R0030-0600-L50	3	0.3	6	50	4	4	0/-0.01	1
VR4S-D0300-R0050-0600-L50	3	0.5	6	50	4	4	0/-0.01	1
VR4S-D0400-R0020-0800-L50	4	0.2	8	50	4	4	0/-0.012	1
VR4S-D0400-R0030-0800-L50	4	0.3	8	50	4	4	0/-0.012	2
VR4S-D0400-R0050-0800-L50	4	0.5	8	50	4	4	0/-0.012	2
VR4S-D0400-R0050-0800-L75	4	0.5	8	75	4	4	0/-0.012	2
VR4S-D0400-R0050-0800-L100	4	0.5	8	100	4	4	0/-0.012	2
VR4S-D0200-R0020-0400-L50-DCON6	2	0.2	4	50	6	4	0/-0.012	2
VR4S-D0200-R0050-0400-L50-DCON6	2	0.5	4	50	6	4	0/-0.012	2
VR4S-D0300-R0020-0600-L50-DCON6	3	0.2	6	50	6	4	0/-0.012	2
VR4S-D0300-R0050-0600-L50-DCON6	3	0.5	6	50	6	4	0/-0.012	2
VR4S-D0400-R0020-0800-L50-DCON6	4	0.2	8	50	6	4	0/-0.012	2
VR4S-D0400-R0050-0800-L50-DCON6	4	0.5	8	50	6	4	0/-0.012	2
VR4S-D0500-R0020-1000-L50-DCON6	5	0.2	10	50	6	4	0/-0.012	2
VR4S-D0500-R0050-1000-L50-DCON6	5	0.5	10	50	6	4	0/-0.012	2
VR4S-D0600-R0020-1200-L50-DCON6	6	0.2	12	50	6	4	0/-0.012	2
VR4S-D0600-R0020-1200-L60-DCON6	6	0.2	12	60	6	4	0/-0.012	2
VR4S-D0600-R0030-1200-L50-DCON6	6	0.3	12	50	6	4	0/-0.012	2
VR4S-D0600-R0030-1200-L60-DCON6	6	0.3	12	60	6	4	0/-0.012	2
VR4S-D0600-R0050-1200-L50-DCON6	6	0.5	12	50	6	4	0/-0.012	2
VR4S-D0600-R0050-1200-L60-DCON6	6	0.5	12	60	6	4	0/-0.012	2
VR4S-D0600-R0100-1200-L50-DCON6	6	1	12	50	6	4	0/-0.012	2
VR4S-D0600-R0100-1200-L60-DCON6	6	1	12	60	6	4	0/-0.012	2
VR4S-D0600-R0020-1200-L75-DCON6	6	0.2	12	75	6	4	0/-0.012	2
VR4S-D0600-R0030-1200-L75-DCON6	6	0.3	12	75	6	4	0/-0.012	2
VR4S-D0600-R0050-1200-L75-DCON6	6	0.5	12	75	6	4	0/-0.012	2
VR4S-D0600-R0100-1200-L75-DCON6	6	1	12	75	6	4	0/-0.012	2
VR4S-D0600-R0020-1200-L100-DCON6	6	0.2	12	100	6	4	0/-0.012	2
VR4S-D0600-R0030-1200-L100-DCON6	6	0.3	12	100	6	4	0/-0.012	2
VR4S-D0600-R0050-1200-L100-DCON6	6	0.5	12	100	6	4	0/-0.012	2
VR4S-D0600-R0100-1200-L100-DCON6	6	1	12	100	6	4	0/-0.015	2
VR4S-D0800-R0020-1600-L60	8	0.2	16	60	8	4	0/-0.015	2
VR4S-D0800-R0030-1600-L60	8	0.3	16	60	8	4	0/-0.015	2

YPMill VR



多材料通用圆鼻铣刀

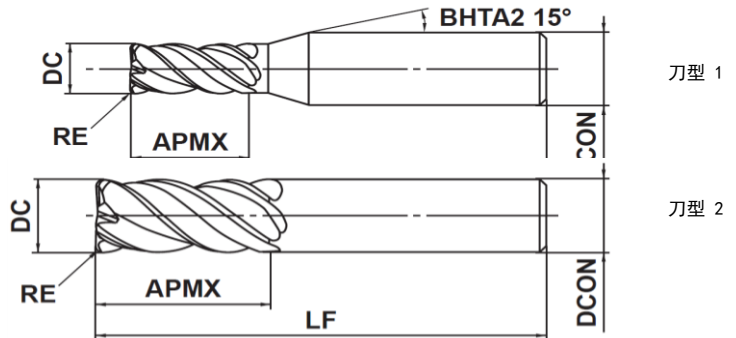

柄部直径公差	h6
螺旋角FHA	37° 40°
刀尖圆弧R公差	±0.02

订货号	尺寸 (mm)					刃数 ZEFZP	DC公差 TCDC	刀型
	DC	RE	APMX	LF	DCON			
VR4S-D0800-R0050-1600-L60	8	0.5	16	60	8	4	0/-0.015	2
VR4S-D0800-R0100-1600-L60	8	1	16	60	8	4	0/-0.015	2
VR4S-D0800-R0020-1600-L75	8	0.2	16	75	8	4	0/-0.015	2
VR4S-D0800-R0030-1600-L75	8	0.3	16	75	8	4	0/-0.015	2
VR4S-D0800-R0050-1600-L75	8	0.5	16	75	8	4	0/-0.015	2
VR4S-D0800-R0100-1600-L75	8	1	16	75	8	4	0/-0.015	2
VR4S-D0800-R0020-2000-L100	8	0.2	20	100	8	4	0/-0.015	2
VR4S-D0800-R0030-2000-L100	8	0.3	20	100	8	4	0/-0.015	2
VR4S-D0800-R0050-2000-L100	8	0.5	20	100	8	4	0/-0.015	2
VR4S-D0800-R0100-2000-L100	8	1	20	100	8	4	0/-0.015	2
VR4S-D0800-R0020-2000-L150	8	0.2	20	150	8	4	0/-0.015	2
VR4S-D0800-R0030-2000-L150	8	0.3	20	150	8	4	0/-0.015	2
VR4S-D0800-R0050-2000-L150	8	0.5	20	150	8	4	0/-0.015	2
VR4S-D0800-R0100-2000-L150	8	1	20	150	8	4	0/-0.015	2
VR4S-D1000-R0020-2000-L75	10	0.2	20	75	10	4	0/-0.02	2
VR4S-D1000-R0050-2000-L75	10	0.5	20	75	10	4	0/-0.02	2
VR4S-D1000-R0100-2000-L75	10	1	20	75	10	4	0/-0.02	2
VR4S-D1000-R0020-2500-L100	10	0.2	25	100	10	4	0/-0.02	2
VR4S-D1000-R0050-2500-L100	10	0.5	25	100	10	4	0/-0.02	2
VR4S-D1000-R0100-2500-L100	10	1	25	100	10	4	0/-0.02	2
VR4S-D1000-R0020-2500-L150	10	0.2	25	150	10	4	0/-0.02	2
VR4S-D1000-R0050-2500-L150	10	0.5	25	150	10	4	0/-0.02	2
VR4S-D1000-R0100-2500-L150	10	1	25	150	10	4	0/-0.02	2
VR4S-D1200-R0020-2400-L75	12	0.2	24	75	12	4	0/-0.02	2
VR4S-D1200-R0050-2400-L75	12	0.5	24	75	12	4	0/-0.02	2
VR4S-D1200-R0100-2400-L75	12	1	24	75	12	4	0/-0.02	2
VR4S-D1200-R0020-3000-L100	12	0.2	30	100	12	4	0/-0.02	2
VR4S-D1200-R0050-3000-L100	12	0.5	30	100	12	4	0/-0.02	2
VR4S-D1200-R0100-3000-L100	12	1	30	100	12	4	0/-0.02	2
VR4S-D1200-R0020-3000-L150	12	0.2	30	150	12	4	0/-0.02	2
VR4S-D1200-R0050-3000-L150	12	0.5	30	150	12	4	0/-0.02	2
VR4S-D1200-R0100-3000-L150	12	1	30	150	12	4	0/-0.02	2
VR4S-D1400-R0050-2800-L100	14	0.5	28	100	14	4	0/-0.02	2
VR4S-D1400-R0100-2800-L100	14	1	28	100	14	4	0/-0.02	2
VR4S-D1400-R0200-2800-L100	14	2	28	100	14	4	0/-0.02	2
VR4S-D1400-R0050-3500-L150	14	0.5	35	150	14	4	0/-0.02	2
VR4S-D1400-R0100-3500-L150	14	1	35	150	14	4	0/-0.02	2
VR4S-D1400-R0200-2800-L150	14	2	28	150	14	4	0/-0.02	2
VR4S-D1600-R0050-3200-L100	16	0.5	32	100	16	4	0/-0.02	2
VR4S-D1600-R0100-3200-L100	16	1	32	100	16	4	0/-0.02	2
VR4S-D1600-R0200-3200-L100	16	2	32	100	16	4	0/-0.02	2
VR4S-D1600-R0050-4000-L150	16	0.5	40	150	16	4	0/-0.02	2

YPMill VR



多材料通用圆鼻铣刀

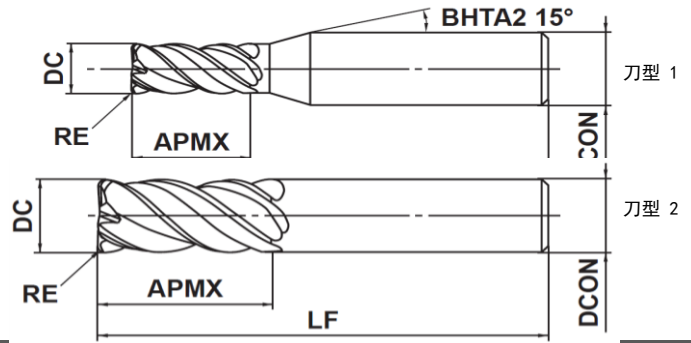

柄部直径公差	h6
螺旋角FHA	37° 40°
刀尖圆弧R公差	±0.02

订货号	尺寸 (mm)					刃数 ZEF	DC公差 TCDC	刀型
	DC	RE	APMX	LF	DCON			
VR4S-D1600-R0100-4000-L150	16	1	40	150	16	4	0/-0.02	2
VR4S-D1600-R0200-4000-L150	16	2	40	150	16	4	0/-0.02	2
VR4S-D1800-R0050-3600-L100	18	0.5	36	100	18	4	0/-0.02	2
VR4S-D1800-R0100-3600-L100	18	1	36	100	18	4	0/-0.02	2
VR4S-D1800-R0200-3600-L100	18	2	36	100	18	4	0/-0.02	2
VR4S-D1800-R0050-4500-L150	18	0.5	45	150	18	4	0/-0.02	2
VR4S-D1800-R0100-4500-L150	18	1	45	150	18	4	0/-0.02	2
VR4S-D1800-R0200-4500-L150	18	2	45	150	18	4	0/-0.02	2
VR4S-D2000-R0050-4000-L100	20	0.5	40	100	20	4	0/-0.02	2
VR4S-D2000-R0100-4000-L100	20	1	40	100	20	4	0/-0.02	2
VR4S-D2000-R0200-4000-L100	20	2	40	100	20	4	0/-0.02	2
VR4S-D2000-R0050-5000-L150	20	0.5	50	150	20	4	0/-0.02	2
VR4S-D2000-R0100-5000-L150	20	1	50	150	20	4	0/-0.02	2
VR4S-D2000-R0200-4000-L150	20	2	40	150	20	4	0/-0.02	2

YPMill YPMS



不锈钢通用铣刀

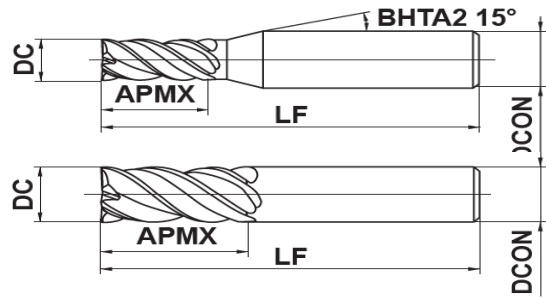

刀型 1

刀型 2

柄部直径公差	h6
螺旋角FHA	不等螺旋
刀尖形状	C角 or R角

订货号	尺寸 (mm)				刃数 ZEFP	DC公差 TCDC	刀型
	DC	APMX	LF	DCON			
以下刀具为C角							
YPMS4S-D0300-C-0800	3	8	50	4	4	0/-0.012	1
YPMS4S-D0400-C-1100	4	11	50	4	4	0/-0.012	2
YPMS4S-D0500-C-1300	5	13	60	6	4	0/-0.012	2
YPMS4S-D0600-C-1600	6	16	60	6	4	0/-0.012	2
YPMS4S-D0700-C-2000	7	20	60	8	4	0/-0.015	2
YPMS4S-D0800-C-2000	8	20	65	8	4	0/-0.015	2
YPMS4S-D0900-C-2200	9	22	75	10	4	0/-0.015	2
YPMS4S-D1000-C-2500	10	25	75	10	4	0/-0.015	2
YPMS4S-D1100-C-2600	11	26	75	12	4	0/-0.02	2
YPMS4S-D1200-C-3000	12	30	80	12	4	0/-0.02	2
YPMS4S-D1400-C-3200	14	32	100	14	4	0/-0.02	2
YPMS4S-D1600-C-4500	16	45	100	16	4	0/-0.02	2
YPMS4S-D1800-C-4500	18	45	100	18	4	0/-0.02	2
YPMS4S-D2000-C-4500	20	45	100	20	4	0/-0.02	2
以下刀具为R角							
YPMR4S-D0400-R0050-1100	4	11	50	4	4	0/-0.012	2
YPMR4S-D0600-R0050-1600	6	16	50	6	4	0/-0.012	2
YPMR4S-D0800-R0050-2000	8	20	60	8	4	0/-0.015	2
YPMR4S-D1000-R0050-2500	10	25	75	10	4	0/-0.015	2
YPMR4S-D1200-R0050-2600	12	26	75	12	4	0/-0.02	2
YPMR4S-D1200-R0100-2600	12	26	75	12	4	0/-0.02	2

YPMill SR

ISO-S 高温合金圆鼻铣刀

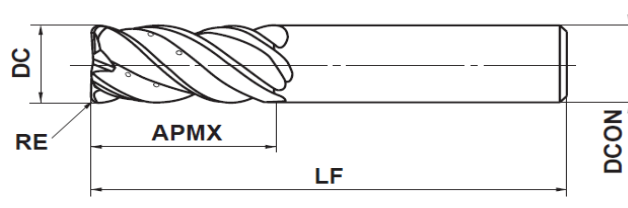

柄部直径公差	h6
螺旋角FHA	50°
刀尖圆弧R公差	±0.02

订货号	尺寸 (mm)					刃数 ZEFP	DC公差 TCDC
	DC	RE	APMX	LF	DCON		
SR4V-D0600-R0050-1300	6	0.5	13	50	6	4	0 / -0.02
SR4V-D0600-R0100-1300	6	1	13	50	6	4	0 / -0.02
SR4V-D0800-R0050-1900	8	0.5	19	60	8	4	0 / -0.02
SR4V-D0800-R0100-1900	8	1	19	60	8	4	0 / -0.02
SR4V-D1000-R0050-2200	10	0.5	22	75	10	4	0 / -0.02
SR4V-D1000-R0100-2200	10	1	22	75	10	4	0 / -0.02
SR4V-D1000-R0200-2200	10	2	22	75	10	4	0 / -0.02
SR4V-D1200-R0050-2600	12	0.5	26	75	12	4	0 / -0.02
SR4V-D1200-R0100-2600	12	1	26	75	12	4	0 / -0.02
SR4V-D1200-R0200-2600	12	2	26	75	12	4	0 / -0.02
SR4V-D1600-R0200-3200	16	2	32	100	16	4	0 / -0.03
SR4V-D1600-R0300-3200	16	3	32	100	16	4	0 / -0.03
SR4V-D1600-R0400-3200	16	4	32	100	16	4	0 / -0.03
SR4V-D2000-R0300-3800	20	3	38	100	20	4	0 / -0.03
SR4V-D2000-R0400-3800	20	4	38	100	20	4	0 / -0.03
SR4V-D2000-R0635-3800	20	6.35	38	100	20	4	0 / -0.03

以下产品刃数5

SR5V-D0600-R0050-1300	6	0.5	13	50	6	5	0 / -0.02
SR5V-D0600-R0100-1300	6	1	13	50	6	5	0 / -0.02
SR5V-D0800-R0050-1900	8	0.5	19	60	8	5	0 / -0.02
SR5V-D0800-R0100-1900	8	1	19	60	8	5	0 / -0.02
SR5V-D1000-R0050-2200	10	0.5	22	75	10	5	0 / -0.02
SR5V-D1000-R0100-2200	10	1	22	75	10	5	0 / -0.02
SR5V-D1000-R0200-2200	10	2	22	75	10	5	0 / -0.02
SR5V-D1200-R0050-2600	12	0.5	26	75	12	5	0 / -0.02
SR5V-D1200-R0100-2600	12	1	26	75	12	5	0 / -0.02
SR5V-D1200-R0200-2600	12	2	26	75	12	5	0 / -0.02
SR5V-D1600-R0200-3200	16	2	32	100	16	5	0 / -0.03
SR5V-D1600-R0300-3200	16	3	32	100	16	5	0 / -0.03
SR5V-D1600-R0400-3200	16	4	32	100	16	5	0 / -0.03
SR5V-D2000-R0300-3800	20	3	38	100	20	5	0 / -0.03
SR5V-D2000-R0400-3800	20	4	38	100	20	5	0 / -0.03
SR5V-D2000-R0635-3800	20	6.35	38	100	20	5	0 / -0.03

注：样本规格以外的需求（特殊直径、刃数、长度等），提供非标订制
切削参数请参考本部分样本的末页

YPMill



模具铣刀 (<HRC55)

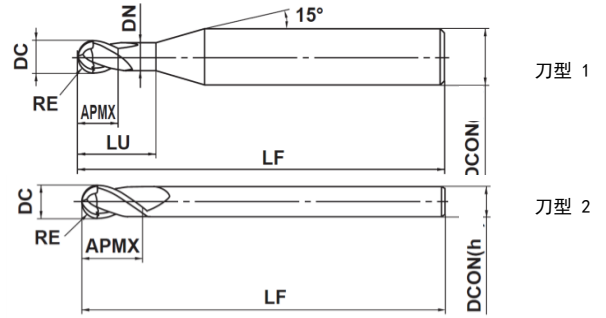

柄部直径公差	h6
螺旋角FHA	30°
球头R公差	±0.005

订货号	尺寸 (mm)							刃数 ZEFP	刀型
	DC	RE	APMX	LF	LU	DN	DCON		
YP-DM1-D0040-R0020-L50	0.4	0.2	0.6	50			4	2	1
YP-DM1-D0050-R0025-L50	0.5	0.25	0.8	50			4	2	1
YP-DM1-D0060-R0030-L50	0.6	0.3	0.9	50			4	2	1
YP-DM1-D0080-R0040-L50	0.8	0.4	1.2	50			4	2	1
YP-DM1-D0100-R0050-L50	1	0.5	0.8	50	2	0.94	4	2	1
YP-DM1-D0150-R0075-L50	1.5	0.75	1.2	50	3	1.42	4	2	1
YP-DM1-D0200-R0100-L50	2	1	1.6	50	4	1.9	4	2	1
YP-DM1-D0250-R0125-L50	2.5	1.25	2	50	5	2.4	4	2	1
YP-DM1-D0300-R0150-L50	3	1.5	2.4	50	6	2.9	4	2	1
YP-DM1-D0400-R0200-L50	4	2	6	50			4	2	2
YP-DM1-D0500-R0250-L50	5	2.5	4	50	12	4.85	6	2	2
YP-DM1-D0600-R0300-L50	6	3	9	50			6	2	2
YP-DM1-D0600-R0300-L60	6	3	9	60			6	2	2
YP-DM1-D0600-R0300-L75	6	3	9	75			6	2	2
YP-DM1-D0600-R0300-L100	6	3	9	100			6	2	2
YP-DM1-D0800-R0400-L60	8	4	12	60			8	2	2
YP-DM1-D0800-R0400-L75	8	4	12	75			8	2	2
YP-DM1-D0800-R0400-L100	8	4	12	100			8	2	2
YP-DM1-D1000-R0500-L75	10	5	15	75			10	2	2
YP-DM1-D1000-R0500-L100	10	5	15	100			10	2	2
YP-DM1-D1200-R0600-L75	12	6	18	75			12	2	2
YP-DM1-D1200-R0600-L100	12	6	18	100			12	2	2

YPMill

模具铣刀 (>HRC55)

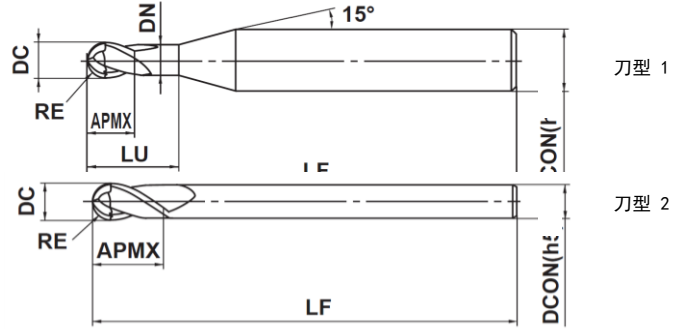

柄部直径公差	h6
螺旋角FHA	30°
球头R公差	±0.005

订货号	尺寸 (mm)							刃数 ZEFP	刀型
	DC	RE	APMX	LF	LU	DN	DCON		
YP-DM2-D0040-R0020-L50	0.4	0.2	0.6	50			4	2	1
YP-DM2-D0050-R0025-L50	0.5	0.25	0.8	50			4	2	1
YP-DM2-D0060-R0030-L50	0.6	0.3	0.9	50			4	2	1
YP-DM2-D0080-R0040-L50	0.8	0.4	1.2	50			4	2	1
YP-DM2-D0100-R0050-L50	1	0.5	0.8	50	2	0.94	4	2	1
YP-DM2-D0150-R0075-L50	1.5	0.75	1.2	50	3	1.42	4	2	1
YP-DM2-D0200-R0100-L50	2	1	1.6	50	4	1.9	4	2	1
YP-DM2-D0250-R0125-L50	2.5	1.25	2	50	5	2.4	4	2	1
YP-DM2-D0300-R0150-L50	3	1.5	2.4	50	6	2.9	4	2	1
YP-DM2-D0400-R0200-L50	4	2	6	50			4	2	2
YP-DM2-D0500-R0250-L50	5	2.5	4	50	12	4.85	6	2	2
YP-DM2-D0600-R0300-L50	6	3	9	50			6	2	2
YP-DM2-D0600-R0300-L60	6	3	9	60			6	2	2
YP-DM2-D0600-R0300-L75	6	3	9	75			6	2	2
YP-DM2-D0600-R0300-L100	6	3	9	100			6	2	2
YP-DM2-D0800-R0400-L60	8	4	12	60			8	2	2
YP-DM2-D0800-R0400-L75	8	4	12	75			8	2	2
YP-DM2-D0800-R0400-L100	8	4	12	100			8	2	2
YP-DM2-D1000-R0500-L75	10	5	15	75			10	2	2
YP-DM2-D1000-R0500-L100	10	5	15	100			10	2	2
YP-DM2-D1200-R0600-L75	12	6	18	75			12	2	2
YP-DM2-D1200-R0600-L100	12	6	18	100			12	2	2

YPMill



模具铣刀 (<HRC55)

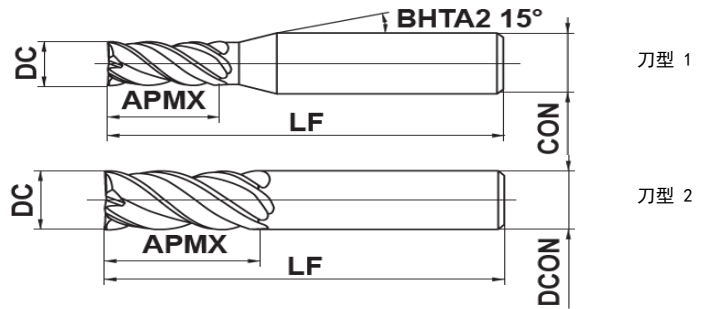

柄部直径公差	h6
螺旋角FHA	36°
刀尖形状	DC≤12, 0.10×45° DC>12, 0.15×45°

订货号	尺寸 (mm)				刃数 ZEFP	DC公差 TCDC	刀型
	DC	APMX	LF	DCON			
YP-DM1-D0040-C-L50	0.4	1.2	50	4	4	0/-0.01	1
YP-DM1-D0050-C-L50	0.5	1.5	50	4	4	0/-0.01	1
YP-DM1-D0060-C-L50	0.6	1.8	50	4	4	0/-0.01	1
YP-DM1-D0080-C-L50	0.8	2.4	50	4	4	0/-0.01	1
YP-DM1-D0100-C-L50	1	3	50	4	4	0/-0.01	1
YP-DM1-D0150-C-L50	1.5	4	50	4	4	0/-0.01	2
YP-DM1-D0200-C-L50	2	6	50	4	4	0/-0.01	2
YP-DM1-D0250-C-L50	2.5	8	50	4	4	0/-0.01	2
YP-DM1-D0300-C-L50	3	8	50	4	4	0/-0.01	2
YP-DM1-D0400-C-L50	4	11	50	4	4	0/-0.012	2
YP-DM1-D0500-C-L50	5	13	50	6	4	0/-0.012	2
YP-DM1-D0600-C-L50	6	16	50	6	4	0/-0.012	2
YP-DM1-D0600-C-L60	6	16	60	6	4	0/-0.012	2
YP-DM1-D0600-C-L75	6	20	75	6	4	0/-0.012	2
YP-DM1-D0600-C-L100	6	20	100	6	4	0/-0.012	2
YP-DM1-D0800-C-L60	8	20	60	8	4	0/-0.015	2
YP-DM1-D0800-C-L75	8	20	75	8	4	0/-0.015	2
YP-DM1-D0800-C-L100	8	25	100	8	4	0/-0.015	2
YP-DM1-D1000-C-L75	10	25	75	10	4	0/-0.015	2
YP-DM1-D1000-C-L100	10	30	100	10	4	0/-0.02	2
YP-DM1-D1200-C-L75	12	30	75	12	4	0/-0.02	2
YP-DM1-D1200-C-L100	12	35	100	12	4	0/-0.02	2

YPMill

模具铣刀 (>HRC55)

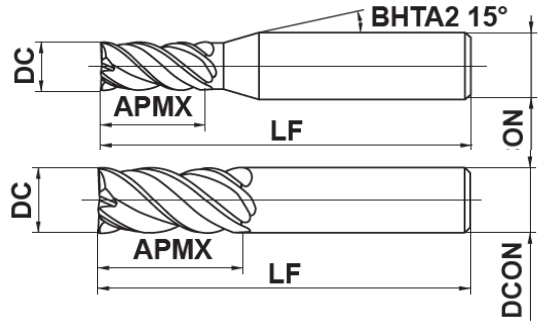

刀型 1

刀型 2

柄部直径公差	h6
螺旋角FHA	36°
刀尖形状	DC≤12, 0.10×45° DC>12, 0.15×45°

订货号	尺寸 (mm)				刃数 ZEFP	DC公差 TCDC	刀型
	DC	APMX	LF	DCON			
YP-DM2-D0040-C-L50	0.4	1.2	50	4	4	0/-0.01	1
YP-DM2-D0050-C-L50	0.5	1.5	50	4	4	0/-0.01	1
YP-DM2-D0060-C-L50	0.6	1.8	50	4	4	0/-0.01	1
YP-DM2-D0080-C-L50	0.8	2.4	50	4	4	0/-0.01	1
YP-DM2-D0100-C-L50	1	3	50	4	4	0/-0.01	1
YP-DM2-D0150-C-L50	1.5	4	50	4	4	0/-0.01	2
YP-DM2-D0200-C-L50	2	6	50	4	4	0/-0.01	2
YP-DM2-D0250-C-L50	2.5	8	50	4	4	0/-0.01	2
YP-DM2-D0300-C-L50	3	8	50	4	4	0/-0.01	2
YP-DM2-D0400-C-L50	4	11	50	4	4	0/-0.012	2
YP-DM2-D0500-C-L50	5	13	50	6	4	0/-0.012	2
YP-DM2-D0600-C-L50	6	16	50	6	4	0/-0.012	2
YP-DM2-D0600-C-L60	6	16	60	6	4	0/-0.012	2
YP-DM2-D0600-C-L75	6	20	75	6	4	0/-0.012	2
YP-DM2-D0600-C-L100	6	20	100	6	4	0/-0.012	2
YP-DM2-D0800-C-L60	8	20	60	8	4	0/-0.015	2
YP-DM2-D0800-C-L75	8	20	75	8	4	0/-0.015	2
YP-DM2-D0800-C-L100	8	25	100	8	4	0/-0.015	2
YP-DM2-D1000-C-L75	10	25	75	10	4	0/-0.015	2
YP-DM2-D1000-C-L100	10	30	100	10	4	0/-0.02	2
YP-DM2-D1200-C-L75	12	30	75	12	4	0/-0.02	2
YP-DM2-D1200-C-L100	12	35	100	12	4	0/-0.02	2

模具铣刀 (<HRC55)



柄部直径公差	h6
螺旋角FHA	37° 40°
刀尖圆弧R公差	±0.02

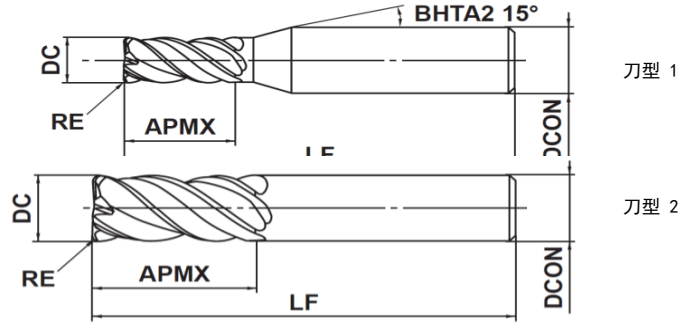

订货号	尺寸 (mm)					刃数 ZEFP	DC公差 TCDC	刀型
	DC	RE	APMX	LF	DCON			
YP-DM1-D0100-R0020-L50	1	0.2	2	50	4	4	0 / - 0.01	1
YP-DM1-D0150-R0020-L50	1.5	0.2	3	50	4	4	0 / - 0.01	1
YP-DM1-D0200-R0020-L50	2	0.2	4	50	4	4	0 / - 0.01	1
YP-DM1-D0300-R0020-L50	3	0.2	6	50	4	4	0 / - 0.01	1
YP-DM1-D0300-R0050-L50	3	0.5	8	50	4	4	0 / - 0.012	1
YP-DM1-D0400-R0020-L50	4	0.2	8	50	4	4	0 / - 0.012	1
YP-DM1-D0400-R0050-L50	4	0.5	8	50	4	4	0 / - 0.012	1
YP-DM1-D0600-R0050-L50	6	0.5	12	50	6	4	0 / - 0.012	1
YP-DM1-D0600-R0050-L60	6	0.5	12	60	6	4	0 / - 0.012	1
YP-DM1-D0600-R0050-L75	6	0.5	12	75	6	4	0 / - 0.012	1
YP-DM1-D0600-R0050-L100	6	0.5	12	100	6	4	0 / - 0.012	1
YP-DM1-D0800-R0050-L60	8	0.5	16	60	8	4	0 / - 0.015	1
YP-DM1-D0800-R0050-L75	8	0.5	16	75	8	4	0 / - 0.015	2
YP-DM1-D0800-R0050-L100	8	0.5	16	100	8	4	0 / - 0.015	2
YP-DM1-D1000-R0050-L75	10	0.5	20	75	10	4	0 / - 0.02	2
YP-DM1-D1000-R0050-L100	10	0.5	20	100	10	4	0 / - 0.02	2
YP-DM1-D1200-R0050-L75	12	0.5	24	75	12	4	0 / - 0.02	2
YP-DM1-D1200-R0050-L100	12	0.5	24	100	12	4	0 / - 0.02	2

YPMill



模具铣刀 (>HRC55)

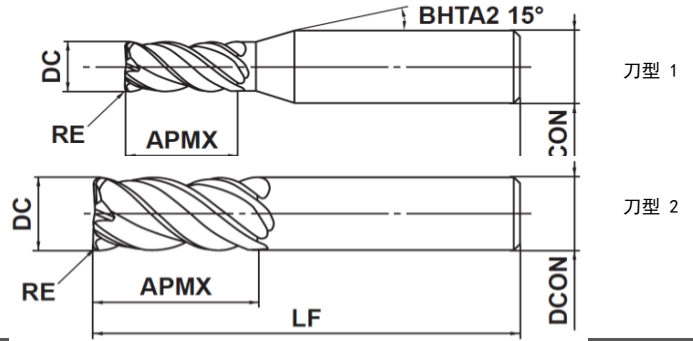

柄部直径公差	h6
螺旋角FHA	37° 40°
刀尖圆弧R公差	±0.02

订货号	尺寸 (mm)					刃数 ZEFP	DC公差 TCDC	刀型
	DC	RE	APMX	LF	DCON			
YP-DM2-D0100-R0020-L50	1	0.2	2	50	4	4	0 / - 0.01	1
YP-DM2-D0150-R0020-L50	1.5	0.2	3	50	4	4	0 / - 0.01	1
YP-DM2-D0200-R0020-L50	2	0.2	4	50	4	4	0 / - 0.01	1
YP-DM2-D0300-R0020-L50	3	0.2	6	50	4	4	0 / - 0.01	1
YP-DM2-D0300-R0050-L50	3	0.5	8	50	4	4	0 / - 0.012	1
YP-DM2-D0400-R0020-L50	4	0.2	8	50	4	4	0 / - 0.012	1
YP-DM2-D0400-R0050-L50	4	0.5	8	50	4	4	0 / - 0.012	1
YP-DM2-D0600-R0050-L50	6	0.5	12	50	6	4	0 / - 0.012	1
YP-DM2-D0600-R0050-L60	6	0.5	12	60	6	4	0 / - 0.012	1
YP-DM2-D0600-R0050-L75	6	0.5	12	75	6	4	0 / - 0.012	1
YP-DM2-D0600-R0050-L100	6	0.5	12	100	6	4	0 / - 0.012	1
YP-DM2-D0800-R0050-L60	8	0.5	16	60	8	4	0 / - 0.015	1
YP-DM2-D0800-R0050-L75	8	0.5	16	75	8	4	0 / - 0.015	2
YP-DM2-D0800-R0050-L100	8	0.5	16	100	8	4	0 / - 0.015	2
YP-DM2-D1000-R0050-L75	10	0.5	20	75	10	4	0 / - 0.02	2
YP-DM2-D1000-R0050-L100	10	0.5	20	100	10	4	0 / - 0.02	2
YP-DM2-D1200-R0050-L75	12	0.5	24	75	12	4	0 / - 0.02	2
YP-DM2-D1200-R0050-L100	12	0.5	24	100	12	4	0 / - 0.02	2

用于通用加工的整体硬质合金平头铣刀



推荐切削参数

方肩铣

铣刀类别	VS				YPMS				VS		VS	
	工件材料		高合金钢、工具钢、预硬钢等 (HRC<40) 例如SKD61、SK、NAK等		奥氏体不锈钢、钛合金 SUS304、SUS316、Ti6Al4V等		高温合金 Inconel718		铝、铝合金、铜、铜合金 A6061、A7050等		淬硬钢 (HRC45-55)	
刀具直径 DC (mm)	线速度VC (m/min)	每齿进给 FZ (mm/tooth)	线速度VC (m/min)	每齿进给 FZ (mm/tooth)	线速度VC (m/min)	每齿进给 FZ (mm/tooth)	线速度VC (m/min)	每齿进给 FZ (mm/tooth)	线速度VC (m/min)	每齿进给 FZ (mm/tooth)	线速度VC (m/min)	每齿进给 FZ (mm/tooth)
3	80	0.03	52	0.02	42	0.01	25.0	0.01	200	0.06	20.0	0.01
4	80	0.04	52	0.03	42	0.02	25.0	0.02	200	0.06	20.0	0.02
5	80	0.05	52	0.04	42	0.02	25.0	0.02	200	0.06	20.0	0.02
6	80	0.06	52	0.05	42	0.03	25.0	0.02	200	0.06	20.0	0.02
8	80	0.08	52	0.06	42	0.04	25.0	0.03	200	0.12	20.0	0.03
10	100	0.1	65	0.08	52	0.05	31.2	0.04	240	0.12	25.0	0.04
12	100	0.12	65	0.10	52	0.06	31.2	0.05	240	0.18	25.0	0.05
14	100	0.12	65	0.10	52	0.06	31.2	0.05	240	0.18	25.0	0.05
16	100	0.12	65	0.10	52	0.06	31.2	0.05	300	0.25	25.0	0.05
18	100	0.12	65	0.10	52	0.06	31.2	0.05	300	0.30	25.0	0.05
20	100	0.125	65	0.10	52	0.06	31.2	0.05	300	0.30	25.0	0.05

*推荐顺铣加工

*任何情况下铣刀短悬伸可以提供最佳刚性

*上表的参数是切宽 $AE < 50\%DC$, 切深 $AP < DC$ 时的起始参数。切宽加大时请适当调整

*因工况不同会有振动发生, 请在保证切屑厚度合理的情况下调整VC和FZ

满槽铣

铣刀类别	VS				YPMS				VS		VS	
	工件材料		高合金钢、工具钢、预硬钢等 (HRC<40) 例如SKD61、SK、NAK等		奥氏体不锈钢、钛合金 SUS304、SUS316、Ti6Al4V等		高温合金 Inconel718		铝、铝合金、铜、铜合金 A6061、A7050等		淬硬钢 (HRC45-55)	
刀具直径 DC (mm)	线速度VC (m/min)	每齿进给 FZ (mm/tooth)	线速度VC (m/min)	每齿进给 FZ (mm/tooth)	线速度VC (m/min)	每齿进给 FZ (mm/tooth)	线速度VC (m/min)	每齿进给 FZ (mm/tooth)	线速度VC (m/min)	每齿进给 FZ (mm/tooth)	线速度VC (m/min)	每齿进给 FZ (mm/tooth)
3	64	0.03	41.6	0.02	33	0.01	20	0.01	160	0.06	16.0	0.01
4	64	0.03	41.6	0.03	33	0.02	20	0.01	160	0.06	16.0	0.02
5	64	0.04	41.6	0.03	33	0.02	20	0.02	160	0.06	16.0	0.02
6	64	0.05	41.6	0.04	33	0.02	20	0.02	160	0.06	16.0	0.02
8	64	0.07	41.6	0.05	33	0.03	20	0.03	160	0.12	16.0	0.03
10	80	0.09	52	0.07	42	0.04	25	0.03	192	0.12	20.0	0.04
12	80	0.10	52	0.08	42	0.05	25	0.04	192	0.18	20.0	0.05
14	80	0.10	52	0.08	42	0.05	25	0.04	192	0.18	20.0	0.05
16	80	0.10	52	0.08	42	0.05	25	0.04	240	0.25	20.0	0.05
18	80	0.10	52	0.08	42	0.05	25	0.04	240	0.30	20.0	0.05
20	80	0.11	52	0.09	42	0.05	25	0.04	240	0.30	20.0	0.05

*普通材料满槽铣最大切深 $ap < 1 \times DC$ *切奥氏体不锈钢满槽铣最大切深 $AP < 0.5 \times DC$ *切高温合金满槽铣最大切深 $AP < 0.2 \times DC$

用于通用加工的整体硬质合金球头铣刀



推荐切削参数

仿形铣

铣刀类别	VB				VB				VB	
	碳钢、铸铁、低合金钢类 (HRC<30) 例如S45C、FC250、SCM等		高合金钢、工具钢、预硬钢等 (HRC<40) 例如SKD61、SK、NAK等		奥氏体不锈钢、钛合金 SUS304、SUS316、Ti6Al4V等		高温合金 Inconel718		铝、铝合金、铜、铜合金 A6061、A7050等	
刀具直径 DC (mm)	线速度VC (m/min)	每齿进给FZ (mm/tooth)	线速度VC (m/min)	每齿进给FZ (mm/tooth)	线速度VC (m/min)	每齿进给FZ (mm/tooth)	线速度VC (m/min)	每齿进给FZ (mm/tooth)	线速度VC (m/min)	每齿进给FZ (mm/tooth)
2	80	0.03	52	0.02	42	0.01	25.0	0.01	200	0.02
3	80	0.04	52	0.03	42	0.02	25.0	0.02	200	0.03
4	80	0.05	52	0.04	42	0.02	25.0	0.02	200	0.03
6	80	0.06	52	0.05	42	0.03	25.0	0.02	200	0.03
8	80	0.08	52	0.06	42	0.04	25.0	0.03	200	0.07
10	100	0.1	65	0.08	52	0.05	31.2	0.04	240	0.07
12	100	0.12	65	0.10	52	0.06	35.0	0.05	240	0.10
14	100	0.12	65	0.10	52	0.06	35.0	0.05	240	0.10
16	100	0.12	65	0.10	52	0.06	35.0	0.05	300	0.12
18	100	0.12	65	0.10	52	0.06	35.0	0.05	300	0.13
20	100	0.125	65	0.10	52	0.06	37.0	0.05	300	0.13

*奥氏体不锈钢和耐热合金材料，推荐使用水溶性切削液

*根据工况和切深对转速和进给做相应调整

*若表面质量不好或者有振动发生，请相应比例的调低VC和FZ

仿形铣

铣刀类别	VB									
	高硬度钢 (<HRC55) NAK、SKD61、SUS420等					高硬度钢 (HRC55-62) SKD11等				
刀具直径 DC (mm)	加工面倾斜≤15°		加工面倾斜>15°		切深AP (mm)	加工面倾斜≤15°		加工面倾斜>15°		切深AP (mm)
	线速度VC (m/min)	每齿进给FZ (mm/tooth)	线速度VC (m/min)	每齿进给FZ (mm/tooth)		线速度VC (m/min)	每齿进给FZ (mm/tooth)	线速度VC (m/min)	每齿进给FZ (mm/tooth)	
1	64	0.03	42	0.04	0.06	51.2	0.03	25	0.04	0.05
1.5	64	0.03	42	0.04	0.09	51.2	0.03	25	0.04	0.08
2	64	0.04	42	0.05	0.11	51.2	0.04	25	0.05	0.10
3	64	0.05	42	0.05	0.13	51.2	0.05	25	0.05	0.12
4	64	0.07	42	0.05	0.15	51.2	0.07	25	0.05	0.13
5	80	0.09	52	0.07	0.20	64	0.09	31	0.07	0.15
6	80	0.10	52	0.08	0.25	64	0.10	31	0.08	0.20
8	80	0.10	52	0.08	0.30	64	0.10	31	0.08	0.20
10	80	0.10	52	0.08	0.50	64	0.10	31	0.08	0.20
12	80	0.10	52	0.08	0.50	64	0.10	31	0.08	0.30
14	80	0.11	52	0.09	0.50	64	0.11	31	0.09	0.30
16	80	0.12	52	0.10	0.50	64	0.12	31	0.10	0.30
18	80	0.15	52	0.10	0.50	64	0.15	31	0.10	0.30
20	80	0.15	52	0.10	0.50	64	0.15	31	0.10	0.30

用于通用加工的整体硬质合金圆鼻铣刀



推荐切削参数

方肩铣

铣刀类别	VR				SR				VR		VR	
	工件材料		高合金钢、工具钢、预硬钢等 (HRC<40) 例如SKD61、SK、NAK等		奥氏体不锈钢、钛合金 SUS304、SUS316、Ti6Al4V等		高温合金 Inconel 718		铝、铝合金、铜、铜合金 A6061、A7050等		淬硬钢 (HRC45-55)	
刀具直径 DC (mm)	线速度VC (m/min)	每齿进给FZ (mm/tooth)	线速度VC (m/min)	每齿进给FZ (mm/tooth)	线速度VC (m/min)	每齿进给FZ (mm/tooth)	线速度VC (m/min)	每齿进给FZ (mm/tooth)	线速度VC (m/min)	每齿进给FZ (mm/tooth)	线速度VC (m/min)	每齿进给FZ (mm/tooth)
3	80	0.03	52	0.02	42	0.01	25.0	0.01	200	0.06	20.0	0.01
4	80	0.04	52	0.03	42	0.02	25.0	0.02	200	0.06	20.0	0.02
5	80	0.05	52	0.04	42	0.02	25.0	0.02	200	0.06	20.0	0.02
6	80	0.06	52	0.05	42	0.03	25.0	0.02	200	0.06	20.0	0.02
8	80	0.08	52	0.06	42	0.04	25.0	0.03	200	0.12	20.0	0.03
10	100	0.1	65	0.08	52	0.05	31.2	0.04	240	0.12	25.0	0.04
12	100	0.12	65	0.10	52	0.06	31.2	0.05	240	0.18	25.0	0.05
14	100	0.12	65	0.10	52	0.06	31.2	0.05	240	0.18	25.0	0.05
16	100	0.12	65	0.10	52	0.06	31.2	0.05	300	0.25	25.0	0.05
18	100	0.12	65	0.10	52	0.06	31.2	0.05	300	0.30	25.0	0.05
20	100	0.125	65	0.10	52	0.06	31.2	0.05	300	0.30	25.0	0.05

*推荐顺铣加工

*任何情况下铣刀短悬伸可以提供最佳刚性

*上表的参数是切宽AE<50%DC, 切深AP<DC时的起始参数。切宽加大时请适当调整

*因工况不同会有振动发生, 请在保证切屑厚度合理的情况下调整VC和FZ

满槽铣

铣刀类别	VR				SR				VR		VR	
	工件材料		高合金钢、工具钢、预硬钢等 (HRC<40) 例如SKD61、SK、NAK等		奥氏体不锈钢、钛合金 SUS304、SUS316、Ti6Al4V等		高温合金 Inconel 718		铝、铝合金、铜、铜合金 A6061、A7050等		淬硬钢 (HRC45-55)	
刀具直径 DC (mm)	线速度VC (m/min)	每齿进给FZ (mm/tooth)	线速度VC (m/min)	每齿进给FZ (mm/tooth)	线速度VC (m/min)	每齿进给FZ (mm/tooth)	线速度VC (m/min)	每齿进给FZ (mm/tooth)	线速度VC (m/min)	每齿进给FZ (mm/tooth)	线速度VC (m/min)	每齿进给FZ (mm/tooth)
3	64	0.03	41.6	0.02	33	0.01	20	0.01	160	0.06	16.0	0.01
4	64	0.03	41.6	0.03	33	0.02	20	0.01	160	0.06	16.0	0.02
5	64	0.04	41.6	0.03	33	0.02	20	0.02	160	0.06	16.0	0.02
6	64	0.05	41.6	0.04	33	0.02	20	0.02	160	0.06	16.0	0.02
8	64	0.07	41.6	0.05	33	0.03	20	0.03	160	0.12	16.0	0.03
10	80	0.09	52	0.07	42	0.04	25	0.03	192	0.12	20.0	0.04
12	80	0.10	52	0.08	42	0.05	25	0.04	192	0.18	20.0	0.05
14	80	0.10	52	0.08	42	0.05	25	0.04	192	0.18	20.0	0.05
16	80	0.10	52	0.08	42	0.05	25	0.04	240	0.25	20.0	0.05
18	80	0.10	52	0.08	42	0.05	25	0.04	240	0.30	20.0	0.05
20	80	0.11	52	0.09	42	0.05	25	0.04	240	0.30	20.0	0.05

*通用材料铣刀满槽铣最大切深 $ap < 1 \times DC$ *奥氏体不锈钢满槽铣最大切深 $AP < 0.5 \times DC$

*高温合金材料不推荐满槽铣